

Vitronics Soltec

Electronic Assembly Equipment

TW EAE

CENTURION Reflow Soldering Solution

Proven Performance from a
Century of Soldering Experience



Best-in-class thermal
performance and improved
sustainability, meeting the most
critical and demanding reflow
requirements in the industry.

Industry's best
heat transfer



CATHOX
CATALYTIC THERMAL OXIDIZER

Vitronics Soltec

CENTURION Reflow Soldering Solutions

The Centurion™ is a forced-convection SMT reflow system with tight, closed-loop process control, built for today's high-throughput PCB assembly environments. With the best heat transfer in the industry, the Centurion is able to run any profile at the lowest set point possible, which minimizes the thermal differences over the product and uses less energy.



Cost effective

Cost of Ownership

With an efficient heat transfer design, Centurion has a low energy consumption rate. Its reliable and robust design, backed by over 20 years of SMT experience and capability, ensures high uptime even with the toughest reflow requirements. Our patented CATHOX™ (Catalytic Thermal Oxidizer) further reduces cost of ownership by reducing the maintenance needs through cutting-edge flux treatment technology. The new 'idle mode' option will further reduce cost of operation.

Industry-leading Thermal Performance

With Centurion's new design backed by our experiences with its prior generations, we achieved better thermal transfer even with a wider process chamber. Our knowledge and experience in process control ensures the repeatability across the oven required by the most demanding customers and the most challenging process requirements in the world.

DUAL LANES WITH INDEPENDENT LANE SPEED CONTROL

Dual lanes with independent conveyor speed control doubles throughput and allows two different boards to run in parallel, a good value for high-mix low-volume manufacturers.

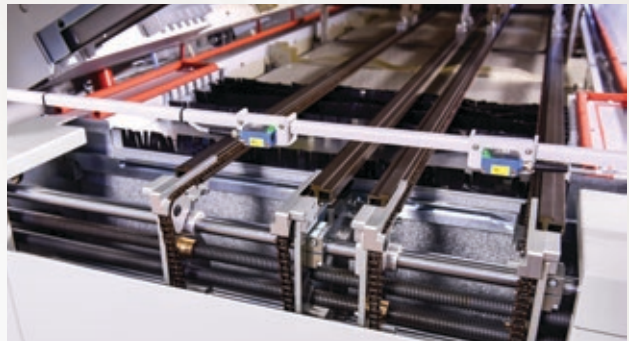

Conveyor Features

- ▶ Dual lane configurations up to 2 x 300 mm
- ▶ Optional combo belt/rail conveyors
- ▶ Single or dual board support systems

Reflow Soldering Solutions

Advanced Features and Options

AIR FLOW SYSTEM

The Centurion air flow system is designed to extract flux contaminated air out of the chamber of an air environment reflow oven. The system isolates the heating and cooling section of the tunnel with an additional venturi. It reduces refresh time and maintenance time, providing a much cleaner environment.



TRUE N₂/AIR SWITCH

The True N₂/Air switch on a nitrogen machine allows the user to easily switch between air flow system and nitrogen flow system for different productions. In Nitrogen production, nitrogen is recirculated to save the operating cost, and in Air production, the new air flow system proactively extracts air out of the chamber to the exhaust box.

This option provides the customer with the combination of a true N₂ machine and a true Air machine.

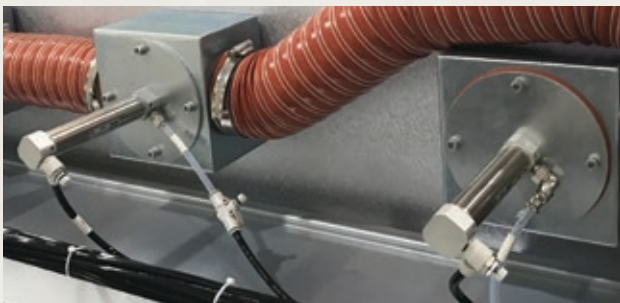

FAST COOL DOWN

Fast changeover time is a key factor for high-mix low volume manufacturers. Fast Cool Down (FCD) is a key option when there are multiple recipe changes in a day, especially when changing profiles from high to low temperature. Through computer program, FCD automatically controls individual zones to reach its specific temperature setpoint.

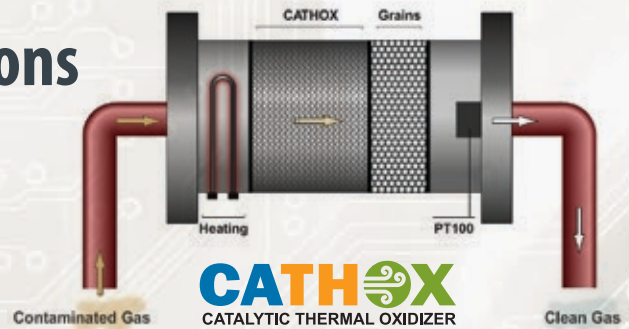

MAINTENANCE AND ACCESSIBILITY

The patented CATHOX™ (Catalytic Thermal Oxidizer) dramatically reduces maintenance requirements while keeping a clean process environment. It is very effective in removing volatile compounds from the process tunnel during reflow. In thermal oxidation, organic vapors are converted to hydrocarbons, which are captured by a filter. Centurion's design also ensures that when maintenance is required, you have easy access and can do the maintenance job with few tools required.

CLOSED LOOP PPM CONTROL SYSTEM

The closed loop PPM control system is designed to be used in a nitrogen environment with CATHOX™ to maintain a precise PPM setpoint range. The closed loop system can maintain the setting from 200PPM to 2000PPM at ± 100 PPM tolerance from 200 to 500 and 20% tolerance from 500 to 2000. In Production Mode, the system ensures stable PCB quality. In Idle Mode, it reduces nitrogen consumption and automatically recovers to PPM setpoint before the machine returns to production.

EASILY REMOVEABLE EXHAUST BOX WITH TEMPERATURE AND PRESSURE MONITORING

The easily removeable exhaust box is part of a flux management solution designed for air or nitrogen environments. This option serves as an alternative flux management solution to Cathox. Filters are easily removed keeping maintenance time to less than two minutes.

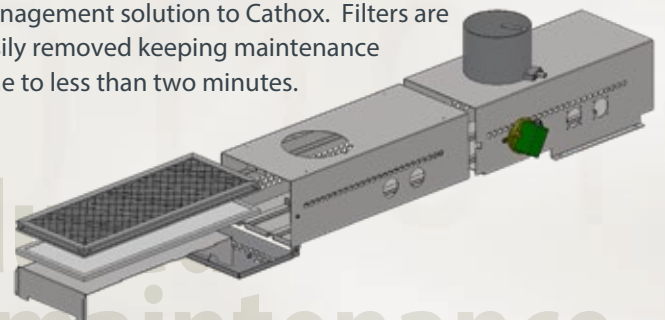

Red
maintenance

Vitronics Soltec

Key standard features

- ▶ Quick exchange heaters and motor fan combination
- ▶ Auto chain lubrication system
- ▶ Board tracking system
- ▶ Power management
- ▶ CE compliance

Motors and Heaters

- ▶ Lifetime warranty
- ▶ Highly reliable

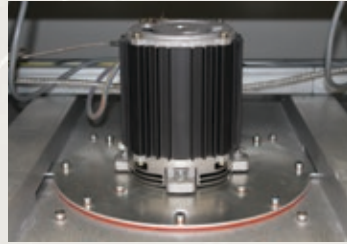

Key optional features

- ▶ CATHOX patented flux management for standard paste users and heavy duty paste users
- ▶ Enhanced zone definition for large zone separation
- ▶ Advanced controlled cooling
- ▶ Dual lane with independent lane speed control
- ▶ True N2/Air Switch
- ▶ Easily Removeable Exhaust Box with Temperature and Pressure Monitoring
- ▶ Fast Cool Down (FCD) option
- ▶ MCA (Machine Capability Analyses) test
- ▶ System performance verification system
- ▶ Traceability and connectivity options

Centurion Specifications

Model Number	CT820	CT930	CT1040	CT1240
Total zones	10	12	14	16
Heating zones	8	9	10	12
Cool zones	2	3	4	4
Total heating length	2840 mm (111.8 in)	3195 mm (125.8 in)	3550 mm (139.8 in)	4260 mm (167.7 in)
System length (AIR)	4150 mm (163.4 in)	4860 mm (191.3 in)	5570 mm (219.3 in)	6280 mm (247.2 in)
System length (N2)	4860 mm (191.3 in)	5570 mm (219.3 in)	6280 mm (247.2 in)	6990 mm (275.2 in)
System width	1600 mm (62.9 in)			
System height	1542 mm (60.7 in)			
Max gas temperature setpoint	350°C			
Gas temperature control accuracy	± 1°C			
Gas thermal uniformity	± 2°C			
Max process width	610 mm (24 in)			
Max dual lane width	300 mm (11.81 in)			
Conveyor speed range	25 - 200 cm/min			
Conveyor speed accuracy	± 1%			
PPM level of N2 machine	<50 PPM			

ITW EAE is a division of Illinois Tool Works, Inc. It is a consolidation of all of its Electronic Assembly Equipment and Thermal Processing Technology. The group includes world-class products from MPM, Camalot, Electrovert, Vitronics Soltec and Despatch.